

**SEPARATOR MAINTENANCE MANUAL. July 06.**

The maintenance of the Separator is the responsibility of the Site Operative.

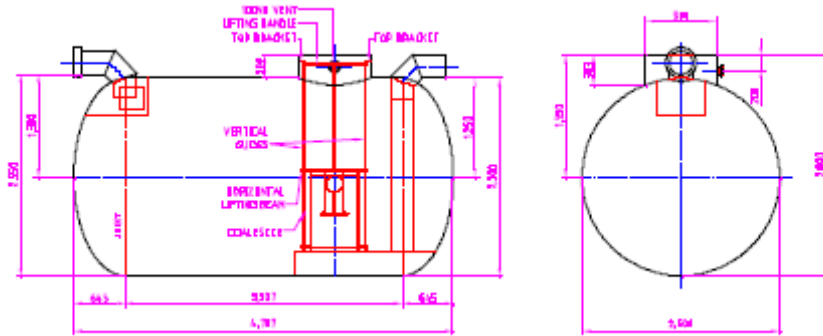

NS 50 Full retention separator

**DO NOT place the tank further underground that the top of the turret supplied on the tank.**





### **IMPORTANT NOTICE RE SEPARATORS (02/06)**

All Bypass & Full retention separators supplied are compliant with the Environmental agency guidelines PPG3 (Pollution Prevention Guidelines) & have been type tested in accordance with clause 8.3 of the EUROPEAN STANDARD BS EN 858-1, SEPARATOR SYSTEMS FOR LIGHT LIQUIDS (EG OIL & PETROL).

- \* 1/3 SMALLER THAN MOST SEPARATORS ON MARKET
- \* REDUCED INSTALLATION COSTS (EXCAVATION & MATERIALS)
- \* REDUCED INSTALLATION TIME

### **Appendix: European Standard Testing Procedure BS EN 858-1**

THE EUROPEAN STANDARD Test is designed to assess the SEPARATING EFFICIENCY of the SEPARATOR by allowing a standard OIL/WATER mixture to flow through the separator at a set rate and measuring the residual oil content in the discharge. For each separate design tests will need to be carried out on at least five REPRESENTATIVE UNITS of that design between or including the smallest size and NS30. The results of these tests can then be used to develop a formula for extrapolating the necessary increase in dimensions for all the component parts to construct larger units. An independent Hydraulics expert must check the accuracy of this formula and its development evidence that such an expert has checked and agrees the formula must be made available to the agencies.

For Separators with a bypass device the oil SEPARATING CHAMBER must pass the performance test. If there is a fundamental difference in the flow path between the BYPASS AND FULL RETENTION Models of a range of Separators, then both full retention and bypass models must be tested as described above.

Each separator will be allocated a nominal size (NS) according to the maximum flow that can be treated to give, under the test conditions, an oil concentration of up to 100 mg/litre (class two) or upto 5 mg/litre (class one) in the discharge.

For example, a Class One NS 20 Separator will achieve a concentration of up to 5 mg/Litres in the discharge at a flow rate of 20 Litres/second under standard test conditions. A Class 2 NS 20 Separator will achieve a concentration of up to 100mg/Litre at 20 Litres/second under the same conditions. As a result, all NS20 Class 2 units will have a similar separating efficiency and, for the same oil and water mixture, will produce discharges of a similar quality while operating at the same flow rate.

### Generic Maintenance – All Types of Separator

It is important to recognise that oil separators (formerly known as interceptors) require regular maintenance to avoid pollution incidents (see Environment Agency's PPG3 clause 7 and the European Standard EN858-2 clause 6). Separators should be inspected by experienced Personnel every six months to determine;

- a. The depth of oil/ light liquid present
- b. The depth of sediment present

A Log should be maintained detailing the above depths, inspection dates, replacement parts, repairs and any cleaning undertaken.

This Log should be made available to the authorities upon request.

- Once a separator has reached its maximum level of oil and or sediment it should be emptied by a waste management contractor. All chambers should be emptied evenly to balance the pressure on internal baffles. The use of warning signs and barriers around the open manholes is recommended.
- KILLARNEY PLASTICS LTD supplied separators are not designed for man entry, however care must be taken whilst being emptied by suction tanker to ensure that damage is not caused to internal components such as filters, closure cartridges and alarm probes which can be situated directly below the manhole access.
- Disposal of the collected contaminants must be in accordance with Environmental Agency and Local authority guidelines.

### NOTE:

- After emptying, the Separator must be immediately refilled with clean water – failure to do so can affect the unit's performance and may cause structural damage.
- Separators should be subject to a full Structural Survey every five years to inspect the following; Structural condition, water tightness of system, internal coatings and state of all inbuilt parts.

## Concrete Surround – CNSB Bypass Separators - BS EN 858

These guidance notes refer only to the installation of Concrete surround CNSB Bypass Separators

Manufactured to BS EN 858 Class 1 and Class 2

These guidance notes cannot provide specific, site-related installation instructions.

If in any doubt whatsoever about any aspect of the installation please us.

### **Pre-Installation Inspection.**

The filter pod in these tanks is held in place during transportation by means of a **Transit Brace**

This is to hold the filter pod in place during transportation and ensure the separator is delivered to site in the same A1 condition as it left our manufacturing facility

**THIS MUST BE REMOVED PRIOR TO INSTALLATION**

Failure to remove the brace may prevent access to the pod for maintenance and

**WILL RENDER THE WARRANTY ON THE TANK INVALID**

The timber transit brace consists of a vertical brace holding the filter pod in place and a horizontal restraining bar.

To remove the brace, unscrew the horizontal restraining bar and remove both pieces of timber

Tanks should be subject to a visual inspection prior to installation

Check the tank is the correct size and duty – see label on tank

Any damage should be notified to the delivery driver and your supplier

Do not attempt to carry out any unauthorised repairs, as this will invalidate the warranty on the tank

Check for, fractures to the shell or ribs, delaminations, scratches or abrasions deeper than 1.5mm, stress cracks or star crazing

Check invert depth is correct and inlet and outlet pipe orientations are correct

### **Service Specification**

**These tanks are designed to be installed below ground and completely surrounded with concrete.**

Generally, the depth from finished ground level to the top crown of the main shell should be no more than 2 metres. This may vary dependant upon ground water conditions. Deeper inverts may be accommodated on a standard shell providing the water table level does not exceed 2 metres above the top crown of the main shell. For deeper burial with high water table conditions heavy-duty shells are available. Should you be in any doubt regarding suitable shell application please call our sales office on 08456 123 332. If the tank is installed outside these parameters it may suffer irreparable damage.

### **Concrete Specification**

The concrete shall be of a sufficient grade, Grade 25N. The specification for the concrete mix to surround the tank may be taken from BS 5328 : Part 1 : 1991 (including amendments), taking into account the site conditions and application requirements. For a typical non-structural application in non aggressive soils a Standard Mix ST4 with a 50mm slump is generally suitable, but also permits the equivalent Designated Mix GEN3 to be specified as an alternative.

If for non typical applications, structural or other reasons a higher than normal designation is required, the purchaser of the fresh concrete can use table 6 in BS 5328: Part 2: 1991 (amendment 8759/October 1995) for guidance.

### **Lift height (rate of rise)**

Determine the lift height (m), or rate of rise (m/h) for the specific concrete type used, to ensure that a design pressure (P max) of 15kN/m<sup>2</sup> on the tank is not exceeded.

### **Vibration**

The design of the tank assumes minimal compaction of the surrounding concrete. Where necessary, this may be extended to include light internal vibration. Never use deep revibration, which will substantially increase the pressure on the tank, possibly causing failure.

### **Impact of Concrete on Discharge**

The effects of impact on discharge are considerable. These are controlled by the vertical form height, the tank diameter and the method of discharge. Under no circumstances should concrete be discharged directly onto the tank.

### **Loadings**

If the tank is installed in an area where traffic or other superimposed loadings can be applied, consult a structural engineer for the design of a reinforced concrete slab to prevent the load being transmitted to the tank (or its concrete surround). If this slab is constructed immediately above the tank, it should be separated from the concrete surrounding the tank by a compressible material.

### **Transportation, unloading and storage of tanks**

1. Tanks must be held down during transportation using nylon straps, do not use cables or chains to hold tanks
2. Do not over tighten straps to cause deformation of the tank shell
3. Tanks are best lifted by crane and webbing lifting straps – do not use chains or wire ropes in contact with the tank.
4. Killarney Plastics Ltd recommends the use of a lifting beam for tanks longer than 8 metres
5. Smaller tanks may be lifted with other suitable site equipment but greater care is needed to control the lift and to ensure the tank is not damaged.
6. Move tanks only by lifting and setting, do not drag or roll
7. Do not drop or roll tanks from truck
8. Tanks are provided with feet, place tanks carefully onto a smooth level even surface, free from rocks, large stones or other debris that could cause point loads.
9. Do not fill tanks or ballast with water whilst above ground, tanks are dependant upon support from concrete backfill to maintain the watertight integrity of the tank
10. In high wind conditions, consideration should be given to strapping down the tanks to prevent damage

### **Installation recommendations.**

Installation procedures must be in accordance with the Health and Safety at Work Act 1974, and other relevant legislation. Your procedures must also align with good building practice.

- 1 Excavate for the tank, allowing sufficient clearance for the minimum concrete surround thickness as shown in the table below, whilst also taking into account any shoring / trench supports used. The depth of the excavation is determined by the inlet and outlet pipe invert levels relative to the bottom of the tank, and allowing for the

minimum base thickness shown. Dimensioned details of the separator can be taken from the relevant drawing. Ground instability at formation level e.g. running sand may necessitate over-excavation and stabilisation with hardcore or blinding concrete.

NOTE: Check that the depth to the base slab is within the Service Specification requirements for the tank.

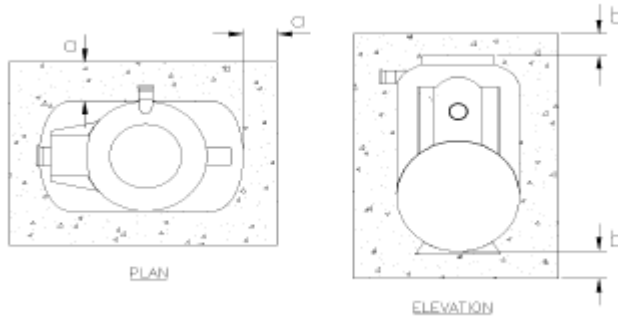

Tank Diameter (mm)	'a' min (mm)	'b' min (mm)
1000	150	150
1200	150	150
1500	200	200
1800	250	250
2500	300	300
3000	300	300
4000	350	300

- 2 Maintain a completely dry excavation until the final pour of concrete has set. Failure to do this may result in voids beneath the tank and subsequent tank failure.
- 3 Pour the concrete into the bottom of the excavation to form a level and smooth base onto which the tank can sit. This should be to the minimum thickness given in the table above.
- 4 Place the tank onto the concrete base, while the concrete is still wet, and determine the correct orientation for the tank inlet(s) and outlet(s), i.e. the higher pipe on the

tank is to be connected to your upstream (inlet) pipework, and the lower pipe on the tank is to be connected to your downstream (outlet) pipework. Connect and seal your pipework to the tank, checking alignment, and ensure that there is an adequate and correct fall for each pipe.

- 5 Fill the separator with clean water to a depth of 300mm and recheck the pipework levels. Commence backfilling evenly around the tank with concrete ensuring there are no voids, particularly at the bottom of the tank shell. Continue filling the chambers with water whilst evenly backfilling with concrete ensuring that the progressive water level is no more than 300mm above the concrete level.
- 6 Connect and seal any turret extensions prior to completing the concrete encasement of the main tank to the height shown in the table. Allow this concrete to set.
- 7 Using appropriate formwork, continue pouring concrete around the tank superstructure (i.e. bypass chamber, access turrets) in lift heights not exceeding 500mm, allowing initial set between each lift. Never increase the lift height or accelerate the rate of rise for the concrete type used, or allow the concrete to be compacted to an extent, which will cause any part of the tank superstructure to distort. If you contravene this warning you will cause damage to the tank.
- 8 Complete backfill to ground level using free flowing material. Trim all access turrets and prepare suitable footings for each manhole frame ensuring that any loads on the covers are not transmitted to the tank access turrets or access extensions, if fitted.

### **Loadings**

The tank has been designed for manweight loading only. If the tank is installed in an area where traffic or other superimposed loadings can be applied, consult a structural engineer for the design of a reinforced concrete slab to prevent the load being transmitted to the tank (or its concrete surround). If this slab is constructed immediately above the tank, it should be separated from the concrete surrounding the tank by a compressible material.

### **Transportation, unloading and storage of tanks**

- Tanks must be held down during transportation using nylon straps, do not use cables or chains to hold tanks
- Do not over tighten straps to cause deformation of the tank shell
- Tanks are best lifted by crane and webbing lifting straps – do not use chains or wire ropes in contact with the tank.

- We recommend the use of a lifting beam for tanks longer than 8 metres
- Smaller tanks may be lifted with other suitable site equipment but greater care is needed to control the lift and to ensure the tank is not damaged.

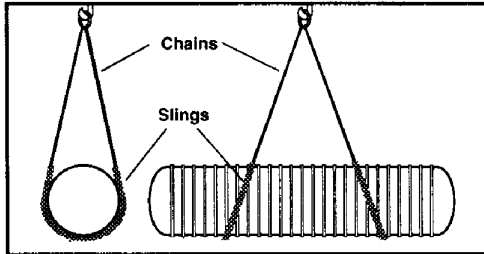

- Move tanks only by lifting and setting, do not drag or roll
- Do not drop or roll tanks from truck
- Place tanks carefully onto a smooth level even surface, free from rocks, large stones or other debris that could cause point loads.
- Chock tanks using tyres, sandbags or similar to prevent rolling

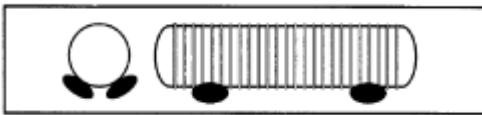

In high wind conditions, consideration should be given to strapping down the tanks to prevent damage

### **Control of Groundwater**

Tanks must not be subjected to buoyant forces during installation, taking account of ground water levels and surface water run-off, and their accumulation in the tank pit, even if tanks are anchored. The excavation should be maintained dry by pumping or whatever suitable means until the concrete surround is cured

### **Access Shaft Extensions**

Access extensions shall be surrounded with concrete poured in 500mm lifts allowing initial set between each lift. The pressure from concrete placed in higher lifts may cause access extensions to distort or collapse.

Please note that loose shafts should be sealed using silicon sealant sikaflex –291 or similar prior to installation to prevent ingress of groundwater under high water table conditions. It is the contractor's responsibility to ensure a watertight seal.

### **Class 1 Separators – units that incorporate Coalescing Filters (FRI inc. ACD . Bypass exc. ACD)**

Coalescing Filters should be replaced at least once a year. If filters are not replaced on a regular basis the filter media will deteriorate and the separator performance will be affected. The filter cartridge should be removed from the separator and inspected on a six monthly basis to ensure that the foam and cartridge are in good condition, the filter does not have any tears and is tightly attached to the cartridge covering all flow holes in the support tube. If in any doubt, replace the filter.

NB: The Filter Cartridge should not be removed if the depth of oil/ light liquid exceeds 90% of the oil storage volume of the separator.

Following inspection the filter cartridge must be firmly pushed into its docking station and locked into place.

Replacement of Filter Tube

- c. With the filter cartridge on a clean smooth surface, remove any lower support disk or cross-bar (immediately above the filter) and slide the tube from the support tube. Cutting the straps will assist this. Place the new filter tube over the support tube to the same position as the old one, ensuring that all flow holes in the support tube are covered properly by the filter
- d. Put two clamping straps (when supplied with replacement filter) over the filter tube 30mm from the top and bottom edges of the filter and tighten these straps very tightly
- e. Replace the cross-bar or support disk if fitted
- f. Fit the chamber back into the separator, push firmly down into docking station and clamp into place
- g. Check that water flows through the separator freely and replace the manhole cover

Separators that incorporate Automatic Closure Devices (ACD) –some units may also incorporate Coalescing Filters

The ACD Cartridge should be removed for inspection every six months to ensure that the float is in good condition and can move unrestricted up and down the cartridge. The

ball/disc should float in water and sink in oil – if this does not happen it should be replaced immediately. Check that the orifice of the docking station is free from sediment and debris.

NB: Do not attempt to remove the ACD cartridge if the oil/ light liquid level exceeds 90% of the oil storage volume of the separator

If the ACD Cartridge proves impossible to lift, the closure device has ‘shut off’ due to one of the following reasons:

- a. The separator is full of oil/ light liquid, and needs to be emptied.
- b. Poor maintenance. Once a waste management contractor has emptied the separator, the ACD cartridge should be removed for inspection. The cartridge should only be repositioned once the separator has been refilled with clean water.
- c. Poor installation. Before installation the ACD cartridge should be removed. During installation the separator should be filled with clean water. The ACD Cartridge should then be repositioned into its docking station and locked into place.

NB: An Automatic Closure Device can only be released from ‘shut off’ position once the separator has been emptied.

Automatic Closure Devices are not fitted in Bypass Separators

### **Separators incorporating Oil Level Alarm Systems**

Alarm systems should be tested and revalidated every six months. The Oil Level Probe should be removed from the separator and cleaned to ensure that there is no debris attached that could affect its performance. Once cleaned the probe should be re-calibrated in the separator by a technician who is familiar with the system to ensure that the alarm will activate when the level of oil reaches 90% of the oil storage volume of the separator under static liquid conditions.

To test the condition of the alarm system press the ‘Push Button’, and the current status will be displayed via the LCD on the front of the unit.

- ‘All Correct’ indicates the levels within the separator are acceptable
- ‘Excessive Oil’ indicates that the unit is in alarm condition

The output relay is de-energised and the small internal piezo sounder is activated. The unit then asks the user, via the display, if they wish to accept/acknowledge the alarm.

On doing so, the output relay energises, the sounder is muted and the display instructs the user to take the appropriate action e.g. Empty the Separator.

It then prompts the user to press the accept push button in order to reset the alarm condition. The control rescans the probe sensors attached and presuming no alarm condition is detected 'All Correct' will display on the LCD. If the push button is pressed before the separator has been emptied, or it has been emptied but not refilled with water the control panel will reinstall the alarm condition.

NB:

The output relay is de-energised on detection of any alarm condition or mains failure

PLEASE CONTACT OUR TECHNICAL SALES DEPT FOR FURTHER  
INFORMATION  
IF UNSURE ON 064 32421

### **MAINTENANCE GUIDE: CNSB Bypass Separator**

#### **INTRODUCTION**

The primary function of oil/water separators is to separate oil, petrol, Diesel and other hydrocarbon contaminants from waste water and retain the separated liquids. These separated liquids must be removed regularly, using a licensed effluent disposal contractor (your contracted service provider), to ensure that the separator operates as efficiently as possible. The natural oil/water separating process from gravity fed waste water depends on the storage, or 'dwell', time within the separator chamber. Guidelines have been established by the Environment Agency\* for minimum 'dwell' times, and hence, minimum working volumes for separators. These have been applied in tests which are based on the maximum flowrate into the separator (l/sec). As the working volume reduces by the accumulation of the separated oil, petrol, Diesel etc., so the separating efficiency reduces.

Another major influencing factor on the efficiency of separator systems is sediment. Oil/water separators are usually designed as liquid/liquid separators unless the specification has determined a requirement to store a volume of sediment. This can be accommodated within a combined liquid/sediment separator where the storage volume is increased accordingly. However, if the design of the drainage system can allow the sediment to be separated and stored upstream of the oil/water separator, in catch-pits or sediment separators, the system would function more efficiently. Again, settled sediment must be removed regularly to ensure optimum efficiency (ref. Environment Agency).

REGULAR MAINTENANCE OF SEPARATOR EQUIPMENT WILL ENSURE IT OPERATES AS INTENDED WITH MINIMUM RISK OF POLLUTION.

### **MAINTENANCE INSPECTIONS**

Separators are used in widely varying circumstances where some will require very frequent maintenance and others will have substantially longer intervals before any maintenance (emptying) is required. However, for every separator regular maintenance inspections should be carried out to determine whether or not there is a need to remove the accumulated oil, petrol, Diesel, etc., or sediment. The owner of the separator is entirely responsible for its operation and ensuring that the effluent quality does not breach any Discharge Consent Standards. It is advisable to set up a 'Service Agreement' with an effluent disposal contractor who can provide 'automatic' and regular maintenance and advise you if any problems with the system occur. The owner is reminded that the existence of a 'Service Agreement' does not necessarily transfer responsibility for general maintenance which must be conducted in accordance with this guide.

The Environment Agency\* has determined that separators shall be inspected at least every six months to establish whether or not emptying is necessary, and a log shall be maintained. Additional equipment for separators provided by KILLARNEY PLASTICS LTD Limited such as an alarm unit will give warning of the accumulation of oil, petrol, Diesel, etc., but should not be used to 'replace' regular inspections.

To keep your CNSB Separator in top condition, we recommend regular servicing by an approved sub contractors who specialise in this field.

### **MAINTENANCE PROCEDURES**

#### **1.0 Health and Safety**

Section 6(a) of the United Kingdom Health and Safety at Work Act 1974 requires manufacturers to advise their customers on the safety and handling precautions to be observed when installing, operating, maintaining and servicing their products. The maintenance procedures described here should be read and fully understood by the operator (competant person) before commencing work. Appropriate personal protective equipment should be used (gloves, goggles, waterproof clothing etc.,) particularly when handling filters which have been in contact with oil and oily sediment.

Before any work commences always identify the separator and its associated manhole covers, and cone off or erect barriers around the entire area.

### **DO NOT ENTER THE TANK**

#### **On receipt of the separator.**

- The filter pod in these tanks is held in place during transportation by means of a Transit Brace. This is to hold the filter pod in place during transportation and ensure the separator is delivered to site in the same A1 condition as it left our manufacturing facility.
- **THIS MUST BE REMOVED PRIOR TO INSTALLATION**
- Failure to remove the brace may prevent access to the pod for maintenance and **WILL RENDER THE WARRANTY ON THE TANK INVALID**
- The timber transit brace consists of a vertical brace holding the filter pod in place and a horizontal restraining bar. To remove the brace, unscrew the horizontal restraining bar and remove both pieces of timber Tanks should be subject to a visual inspection prior to Installation
- Check the tank is the correct size and duty – see label on Tank
- Any damage should be notified to the delivery driver and to Killarney plastics Ltd.
- Do not attempt to carry out any unauthorised repairs, as this will invalidate the warranty on the tank
- Check for, fractures to the shell or ribs, de laminations, scratches or abrasions deeper than 1.5mm, stress cracks or star crazing.
- Check invert depth is correct and inlet and outlet pipe orientations are correct

#### **Incremental maintenance**

If, following maintenance inspections, the separator is found to be storing the maximum volume of oil, petrol, Diesel etc., or the maximum volume of sediment, inform your licensed effluent disposal contractor who will arrange for emptying. The following are guidelines only for determining the maximum storage volumes of oil and sediment.

- Multiply the maximum flowrate for which the separator has been designed (l/sec) by 15. This will be the maximum storage volume of oil in litres e.g. a CNSB15 separator is designed for a 15 l/sec flowrate, therefore, can store 225 litres of oil.
- Where no specific sediment volumes have been determined for the separator, or where no sediment has been expected to accumulate in the system, the maximum stored depth of sediment should not exceed 20% of the depth of the separator

barrel e.g. a 1.8m diameter separator should not store more than 360mm depth of sediment.

### Procedure

- Apply the Health and Safety requirements detailed in Section1 before commencing any work.
- Isolate the separator from the drainage system either by closing pre-installed valves in the upstream and downstream manholes or by securely fitting proprietary pipeline stoppers.
- Slowly lift out the coalescing filter pod assembly. This should be lifted at a rate of 20mm per second (1.2m per minute), until clear of the water, ensuring that most of the residual water is drained from the coalescing filter. This will also reduce the combined overall weight of the assembly.
- **NOTE:** This assembly could weigh up to 55kgs and should be handled by two persons unless a mechanical hoist (recommended) is being used.
- Remove the coalescing filter pod assembly to a place of safe keeping.
- Using a licensed effluent disposal contractor (your contracted service provider) carry out the following:
  - Remove the oil, petrol, Diesel etc., from the surface of the liquid, leaving as much of the cleaner water as possible in the separator. Remove the sediment from the bottom of the separator taking great care in and around the filter outlet housing on the base to ensure that it does not become damaged, again leaving as much of the cleaner water as possible in the separator
  - Move the filter pod assembly to a convenient position upstream of the separator so that any polluted water washed from the filter will be directed back to the separator. Wash the filter using a low pressure hose. If the filter has become 'blinded' with sediment or it is too dirty to clean or has become damaged, replace it.
  - Fill the separator with clean water up to the outlet invert level.
  - Slowly lower the filter pod assembly into the separator and push home to ensure it is fully seated and sealed.
  - Check that the Hydrocarbon alarm probe has not been damaged and that the alarm system is working correctly by operating the test programme described in the Operational Guide.
- Replace the manhole covers and remove the cones and/or barriers from the worksite.

**REMEMBER –**

if the alarm system activates due to the accumulation of oil, petrol, Diesel etc., do not delay in contacting your licensed effluent disposal contractor. It may be several days before emptying can be arranged due to the necessity to prepare and present notifiable waste certificates.

1. In accordance with Killarney Plastics Ltd normal policy of product development, this specification is subject to change without notice.
2. The sale and or distribution of this product is subject to Killarney Plastics Ltd standard Terms and Conditions, available upon request.

**Also by Killarney plastics Ltd.**

- Sectional water tanks.
- One-piece water tanks, 45 litres to 9092 litres
- Tri-Cel P6 single house Bio Systems
- Tri-Cel large multi house development Bio Systems
- Distribution boxes.
- Separators – Petrol / oil interceptors
- Underground tanks
- Underground rainwater tanks
- Kiosks
- ESB meter cabinets - Gas meter cabinets
- Agri Box - IP65 Metering cabinets
- Cable ETU Box
- Insulated housings.
- Chemical tanks
- Shower trays
- Safety products.

**Killarney Plastics Ltd.  
Ballyspillane Ind Est,  
Killarney,  
Co. Kerry,  
Ireland.**

**Tel: +353 (0) 64-32421**

**Fax: +353 (0) 64-22686**

**e-mail: [sales@killarneyplastics.com](mailto:sales@killarneyplastics.com)**

**web: [www.killarneyplastics.com](http://www.killarneyplastics.com)**

**web: [www.tricel.ie](http://www.tricel.ie)**