



# **Sectional Cold Water Storage Tank**

## **Installation & Maintenance Instructions**

Rev : 1.5

Nicholson Plastics Ltd,  
Riverside Road, Kirkfieldbank, Lanark.  
Phone No.: 01555-664316 Fax No.: 01555-663056  
e-mail : [sales@nicholsonplastics.com](mailto:sales@nicholsonplastics.com)  
web : [www.Nicholsonplastics.com](http://www.Nicholsonplastics.com)



---

---

# Index

	Page
1. Guide Lines on Locating tanks	4
2. Guide Lines for different models of tanks	5
3. Data Sheets	
i Insulated Tanks	6
ii Vents & Overflows	7
iii Condensation/Drip Trays	8
iv Ball Valve Housings	9
v Connections	10
4. Base Details	
Metric Tanks	12
Imperial Tanks	13
5. Maintenance Procedures	14
6. Glossary of terms	15

## Note :

- Guarantees are only valid if tanks are installed and maintained strictly in accordance with the following instructions.
- Copies of Maintenance and Installation instructions should be passed on to the end user.
- The end user should ensure that tanks are maintained in accordance with BS 6700.
- Guarantees are only valid if appropriate overflows are fitted, failure to fit overflows can lead to tanks operating at greater pressures than they are designed for.

# Guidelines for Locating Water Tanks

## General

The following recommendations are generally for elevated tanks, as tanks at elevated positions can cause serious damage to the surrounding area in the event of wall, pipe or structural support failure resulting in water spilling out at a fast rate. Consideration must be given to minimise the effects of such an occurrence, in terms of the positioning of the tank and regular inspection for defects.

- Water tanks should be located so as to prevent water damage or consequential loss in the event of leakage howsoever occurring.
- All tanks which are located above water sensitive areas should have a bund wall around them with adequate evacuation ducts.
- All other tanks should have Condensation or Drip trays to prevent nuisance damage and to keep floors dry.

Over the years we have seen tanks fail due to age, lack of maintenance, failure of the structural supports underneath the tanks, contaminated water attacking the internal fittings, ball valve failure where overflows were not fitted, vandalism etc.

## Handrails on Tank Roofs - Health & Safety Requirements

Handrails may be necessary to satisfy Health & Safety Regulations. The type of railing required is dependant on the tank height, distance from ground level, access etc. Please confirm which handrail arrangement is required so that we can make the necessary inclusion. Nicholson Plastics can supply and install ladders and railings but we must be informed of the exact details prior to quoting the job. We assume that the end user is making his own arrangements unless we are informed otherwise.

## Water Tanks on top of Buildings

Water tanks located on top of any building should be sited at least 1.2 meters away from the edge of the building.

It would be preferable if the water tank was sited 1.5 times the height of the tank away from the edge of the building. In the event of failure, this would allow the water to spread itself over a much wider area before spilling over the edge of the building and possibly taking personnel or debris with it.

## Water Tanks on Elevated Structures

For water tanks located on top of elevated structures, a walkway of at least 1 meter should be provided all round the water tank to allow for maintenance and inspection. This walkway should comply with health and safety regulations.

## Potable Water Tanks

To comply with the Health & Safety Executive regulations on the Control of Legionellosis 1998, Cold Water Storage Tanks must be located in areas that are “*readily accessible for cleaning*”.

Regular Maintenance and Inspections as required by Health & Safety Legislation.

## Guidelines for different models of tanks

**Standard Tank :** This tank is complete with internally flanged base, externally flanged side walls. All under water stays are Stainless Steel and all bolts are Galvanised to BS 729.

**Light Weight Cover :** Only suitable for indoor use, and for the storage of foul water. They are not designed to take human weight.

**Heavy Duty Cover :** Suitable for Indoor and Outdoor Use, and for the storage of foul water. These tanks have internally flanged lid panels, similar to those used in the base.

**Heavy Duty Cover and Finished to Byelaw 30 :** Suitable for Indoor, Outdoor use and for the storage of Drinking Water, as defined in our specification Nicholson Plastics 30 on page 5.

### Note :

- To comply with current legislation all tanks that store water that may be used for drinking must be protected, they must meet the requirements set out in the water byelaws
- BS 6700 states that because any cold water tap is likely to be used to drink from, all such taps not directly connected to the mains shall be supplied only from tanks that are protected.
- Where drinking water has been stored in an inadequately protected tank, a water analysis should be considered and adequate protection installed.
- Tanks of over 1000 litres (220 gallons) shall be divided or have standby tanks to facilitate repairs and maintenance. It should also have a wash out pipe or drain out taps, these to terminate above an outside gully to prevent wastage.
- Tank insulation materials should not suffer permanent structural damage from contact with water generally Phenolic and Polyurethane closed cell foams comply. Where pipe cut outs go through insulation panels, bezels should be fitted to protect the exposed insulation from the ingress of moisture, insects and vermin and preserve the integrity of the insulation with a protective finish.

**Types of Bolts :** Standard Tanks come complete with Bolts galvanised to BS 729, we recommend that Consultants specify Stainless Steel grade 316 S16 bolts under water.

**Dividers :** In any situation where there is only one water storage tank in a building and the capacity is greater than 1000 litres (220 gallons), BS 6700 states *“To avoid interruption of the water supply when carrying out repairs or maintenance, the cistern shall be provided with compartments or standby cistern”*. Where drinking water is being stored, two separate tanks are recommended as it is difficult to detect cross contamination from one side of a division wall to another.

**Condensation Drip Trays :** They should be used in any instance where condensation, drips from pipe work, or from the tank could cause nuisance damage or render floors wet and slippery.

**Ball Valve Housing :** Enclosed chamber containing an access hatch above the level of the cover, permitting the level control mechanism to be mounted at a higher level than would otherwise be possible. The overflow(s) must be placed on the tank side wall and not on the Ball Valve Housing. Water must be kept below tank roof level. Ball Valve Housings are only necessary where very large ball valves are used.

**Ladders :** Where tank depth is 1.5 m or greater, internal and external ladders should be specified. If the tank is on a raised platform then ladders may be required on tanks lower than this height.

**Reverse Base Tanks :** (Externally flanged base) These types of tanks allow the tank to be totally drained down, as the base is flat, they also allow access to all the bolts from outside the tank. 450 mm clearance is required underneath the tank for access to the base bolts.

## Tanks Insulated and finished to Byelaw 30

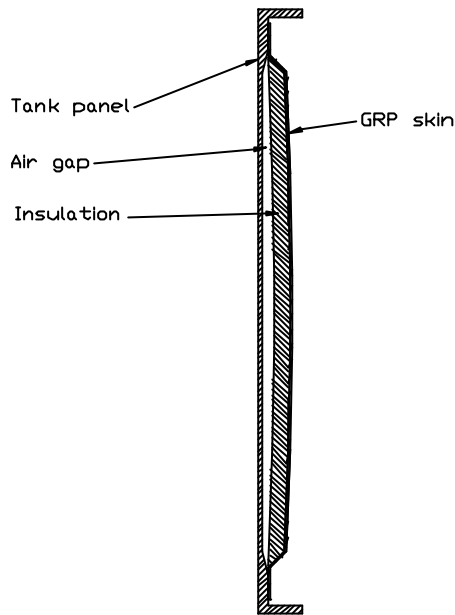

**Note :** This is only an example of one type of insulation skin, there are different arrangements for different types of tanks.

- Current legislation states that water hot or cold, in any premises that might be used for human consumption must be of potable quality.
- In addition to tank material specifications, there are now further requirements for lid design, the screening of vents, breathers, overflows, warning tell tale pipes and the provision of insulation which will help prevent freezing and also help keep water as cool as practicable, ideally less than 20°C.
- Byelaw 30 is Nicholson Plastics description of tanks with Heavy Duty panel covers, complete with screened vents, overflows, warning pipes etc and having side wall and roof panels with a (u) value of 2.5 w/m<sup>2</sup>K, (tanks under 1m high have a slightly higher value). This value meets the requirements of section 30 of the water bye laws in the majority of situations. Tanks in boiler rooms etc may also need base insulation. The purchaser can specify extra requirements or thermal transmittance after considering the period of protection necessary, the tank location and the surrounding conditions.

**Please Note :** Insulation slows down but does not prevent heat loss or gain over protracted periods. Additional information is available in BS 7491 & BS 6700.



10150 x 2150 x 1500 mm 30,000 Litre (6,600 Gallons) Water Tank, Insulated to Byelaw 30

# Format 30 Fittings

## Screened Air Inlet Vent.

One of these is to be fitted to the lid in every Heavy Cover and Byelaw 30 Tank, the hole for the vent will be pre-drilled in the lid panel. Larger tanks may require more than one vent. Tanks with dividers to roof will require two number vents. Vent configuration may vary from that shown.

**Note :** During commissioning the air inlet vent should be checked to ensure that it is attached correctly to the tank.

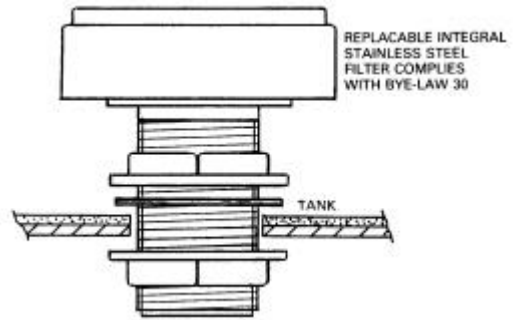

## Screened Overflow

A screened overflow should be supplied with each Byelaw 30 Tank. Please contact us with size is required. These are not fitted by Nicholson Plastics Ltd unless specifically requested.

Overflows larger than 1 1/2 " have a different configuration.

Warning or tell tale pipes if specified must also be screened.

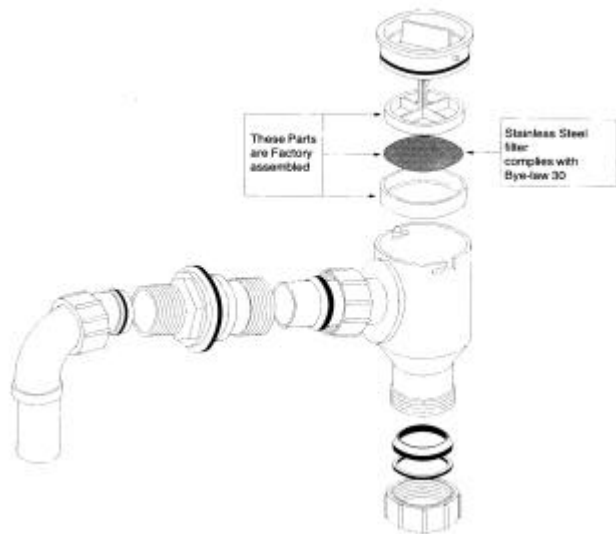

Bye Law 30 fittings for larger commercial installations.

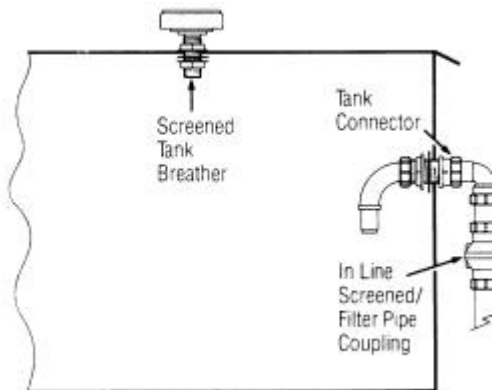

Bye Law 30 fittings for domestic storage tanks.

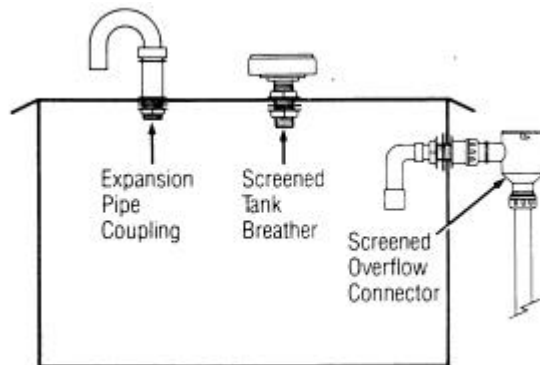

## Condensation/Drip Trays

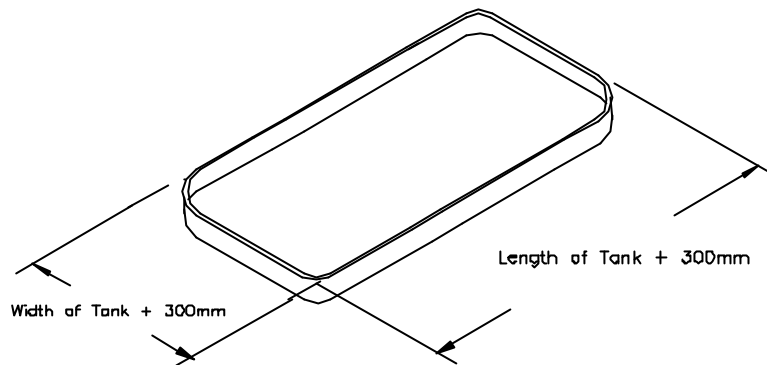

Nicholson Plastics manufacture condensation/drip trays to suit all sizes of Water Storage Tanks. For Sectional cold water storage tanks, the tray extends round the tank by 150 mm. i.e. a sectional tank with internal dimensions 4000 x 3000 mm will have a tray approximately 4300 x 3300 x 100 mm high.

Trays for large sectional tanks are joined on site.

Condensation Trays should be used in any instance where condensation, drips from pipe work or from the tank could cause nuisance damage or render floors wet and slippery.

Condensation trays should be water tested at time of testing tank.

**A condensation tray is not a substitute for a bund wall or for tanking out a room.**

**APPROPRIATE OVERFLOWS MUST BE FITTED AS CLOSE AS POSSIBLE TO THE BASE OF THE TRAY. THESE MUST BE FITTED BEFORE THE TANK IS FILLED.**

## BALL VALVE HOUSING

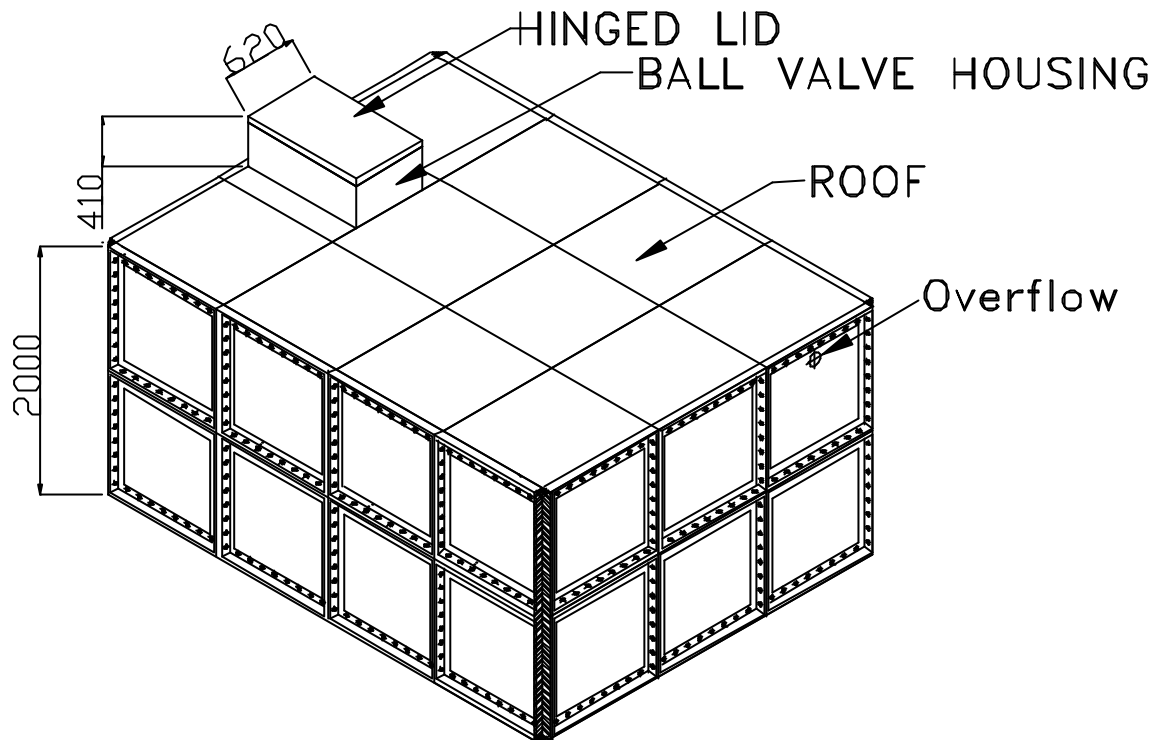

All dimensions are in mm

Isometric view of a Ball Valve Housing on a 4000 x 3000 x 2000 mm Sectional cold water storage tank.

A Ball Valve Housing is an enclosed chamber containing an access hatch above the level of the cover, which leaves space for larger ball floats to raise up and shut off the water supply.

### Specification

External Dimensions : 1000 x 620 x 410 mm high

Space required : 1000 mm clearance space is required above the roof of the tank,  
i.e. For a 2m high tank the room needs to be 3000 mm high.

**Note : The overflow(s) must be placed on the tank side wall and not on the Ball Valve Housing. Water must be kept below tank roof level.**

## Pipe Connections for Cold Water Storage Tanks.

- If the tank is to be drained down at a fast rate or by pumps etc, Nicholson Plastics should be contacted so that adequate vents can be placed on the tank. The standard vent is 2".
- Connections of 100mm (4") nominal bore or over require studed flange pads to suit BS 1962, table D&E flanges for pipework connections.
- Connections below 100mm (4") nominal bore may be made by cutting holes in situ. First determine whether single or double sided connections are required and cut hole in panel to suit external pipe diameter.
- For connections over 50 mm (2") nominal bore use two flanges screwed BS21 taper thread, drilled to BS 10. Offer one flange to panel concentric with hole and transfer drill bolt holes into panel. Set one flange to external pipe and using appropriate gaskets, assemble external flanged pipe using other flange as an internal backing plate. Finally bolt up.
- For double sided connections proceed as above, replacing internal flange with the required fitting, e.g. ball valve, strainer basket etc.
- For connections of 50 mm (2") nominal bore or less proceed as above or alternatively use threaded flanges or backnuts (with rubber gaskets) on standard longcrew to BS 1387.

The figures below show hole diameter for in situ pipe fittings and minimum dimensions for the location of connections from panel edges.

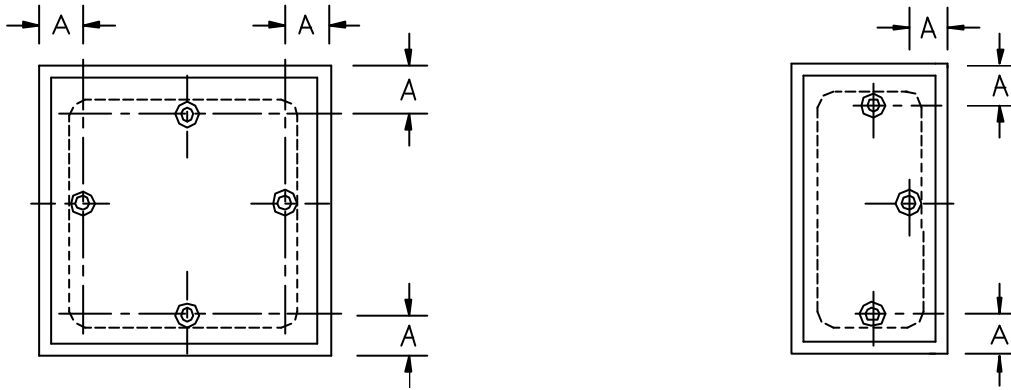

Nominal Bore Diameter	Nominal Hole Size	Dimension A
12.7 (1/2)	22 (7/8)	158 (6 1/4)
19 (3/4)	28 (1 3/32)	161 (6 3/8)
25.4 (1)	35 (1 3/8)	167 (6 5/8)
31.7 (1 1/4)	44 (1 31/32)	170 (6 3/4)
38.1 (1 1/2)	50 (1 31/32)	177 (7)
50.8 (2)	61 (2 13/32)	186 (7 3/8)
63.5 (2 1/2)	78 (3 1/16)	193 (7 5/8)
76.2 (3)	90 (3 9/16)	202 (8)
89 (3 1/2)	105 (4 1/8)	212 (8 3/8)

millimetres/inches

### General Notes

All pipe work must be self supporting. If welded or brazed-on flanges are used, all heat must be dissipated before connections are made to the tank. Holes may be cut with normal metal working tools.

**Note:** These figures only apply to Uninsulated Tanks

## Pipe Connections for Insulated Cold Water Storage Tanks.

The areas where pipe connections can be made on insulated tanks are more restricted than in standard tanks, the picture below shows a recess in the insulation panel to allow for the pipe connection. Standard insulated tanks come with three insulation panels with recesses. More can be supplied if required.



The recesses have a diameter of 180 mm, they are located centrally on the vertical axis, the centre of the recess is 205 mm from the edge of the panel on Metric tanks and [170 mm from the edge of the panel on Imperial tanks](#).

The recesses have the same dimensions on half panels.

Recesses for connections can be made in different locations but Nicholson Plastics must be notified of this prior to order.

## Base Details /Design Considerations (METRIC)

Tanks based on 1x1 & 1x.5 m panels

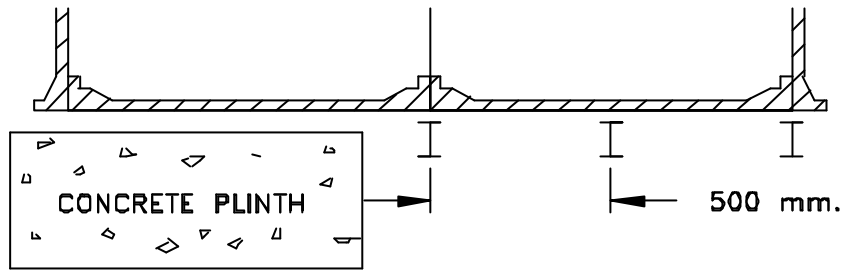

Standard base tanks (internally flanged base panels) may be laid directly on a concrete plinth having a trowelled finish, brushed clean and free from any local protuberances. It should be flat, level and not vary more than 6 mm in any 6 m, measured laterally or diagonally with a maximum variance of 2 mm per metre. The plinth must exceed the nominal tank dimensions by a minimum of 175 mm.

Tanks erected on elevated structures (RSJ beams or brick courses in one direction only). Bearers must be at 500 mm centres. Bearer length must exceed nominal tank dimensions by a minimum of 150 mm plus any extra for fixings. All bearer walls to be flat and level. For bearer width see chart below.

### Typical Tank Room (Plan)

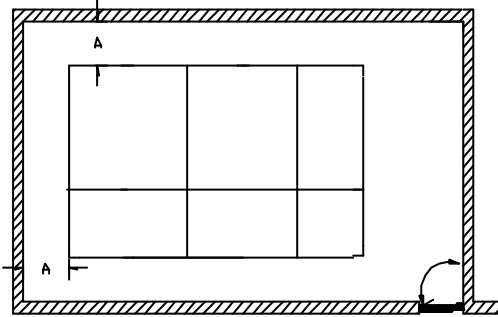

For dimension 'A' see chart below. This clearance should be on all sides of the tank, also a top clearance of 650 mm is required for standard access hatch to open. (This can be reduced to 450 mm provided that Nicholson Plastics is notified prior to dispatch). If the tank has to be pushed closer to any wall after assembly or if the working space is reduced (dimension 'A') at a later stage, by the building of walls etc, responsibility will rest with others.

### Example : Tank where base is 2650 x 1650 mm

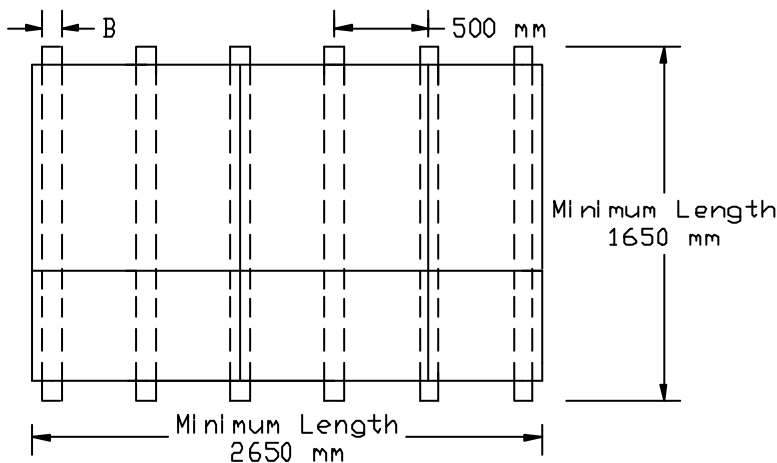

### General Notes:

1. Tanks should not be placed above / beside water sensitive areas, unless there is adequate bunding.
2. Client to design suitable bearers to suit load conditions. Water load =  $1000 \text{ kg/M}^3 + 20\%$  for tank.
3. Bearers can run in either direction.
4. It is necessary that the top of each bearer be flat, level and level with it's neighbouring bearers.
5. Deflection must not exceed  $1/500^{\text{th}}$  of the unsupported span of the bearers. The unsupported span can only be in one direction.
6. Adequate overflows should be fitted to prevent the tank from being pressurised.
7. Tanks in exposed places may be susceptible to movement in high winds, especially when empty. These may need to be anchored to the base, this work is to be carried out by others.

### Working Space and Bearer Width

Tank Height	Dimension 'A'	Bearer Width 'B'
Mm	Mm	mm
500	450	75
1000	450	100
1500	500	100
2000	600	150
2500	650	150
3000	700	150

## Base Details /Design Considerations (IMPERIAL)

Tanks based on 1.22m x 1.22m & 1.22m x.61m panels

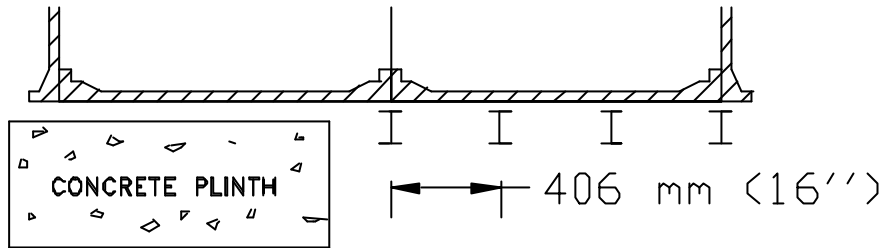

Standard base tanks (internally flanged base panels) may be laid directly on a concrete plinth having a trowelled finish, brushed clean and free from any local protuberances. It should be flat, level and not vary more than 6 mm in any 6 m, measured laterally or diagonally with a maximum variance of 2 mm per metre. The plinth must exceed the nominal tank dimensions by a minimum of 175 mm.

Tanks erected on elevated structures (RSJ beams or brick courses in one direction only). Bearers must be at 406 mm (16'') centres. Where a half panel is used one bearer at 610 mm (24'') centres is required. Bearer length must exceed nominal tank dimensions by a minimum of 150 mm plus any extra for fixings. All bearer walls to be flat and level. For bearer width see chart below.

### Typical Tank Room (Plan)

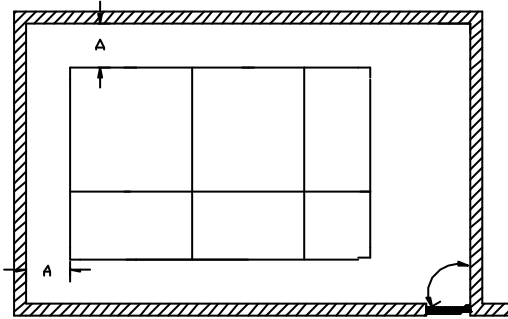

For dimension 'A' see chart below. This clearance should be on all sides of the tank, also a top clearance of 650 mm is required for standard access hatch to open. (This can be reduced to 450 mm provided that Nicholson Plastics is notified prior to dispatch). If the tank has to be pushed closer to any wall after assembly or if the working space is reduced (dimension 'A') at a later stage, by the building of walls etc, responsibility will rest with others.

**Example :** Tank base is 3200 x 1980 mm  
( 10'6'' x 6'6'' )

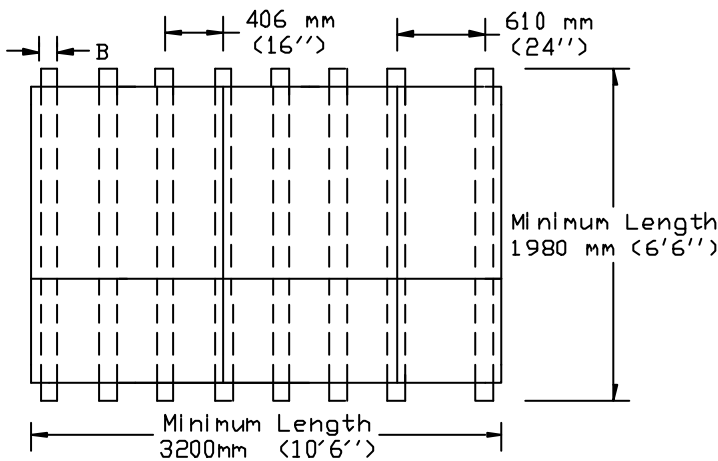

### General Notes:

1. Tanks should not be placed above / beside water sensitive areas, unless there is adequate bunding.
2. Client to design suitable bearers to suit load conditions. Water load =  $1000 \text{ kg/M}^3 + 20\%$  for tank.
3. Bearers can run in either direction.
4. It is necessary that the top of each bearer be flat, level and level with it's neighbouring bearers.
5. Deflection must not exceed  $1/500^{\text{th}}$  of the unsupported span of the bearers. The unsupported span can only be in one direction.
6. Adequate overflows should be fitted to prevent the tank from being pressurised.
7. Tanks in exposed places may be susceptible to movement in high winds, especially when empty. These may need to be anchored to the base, this work is to be carried out by others.

### Working Space and Bearer Width

Tank Height	Dimension 'A'	Bearer Width 'B'
Mm	mm	Mm
610	450	75
1220	450	75
1830	500	75
2440	600	150

# **Maintenance Recommendations for Sectional Water Storage Tanks**

**Maintenance Interval :** Annually

## **Check List**

1. All internal supports should be checked for corrosion, if corrosion is found it should be rectified immediately.
2. Check generally for leaks or drips.
3. Check that all pipe work connected to the tank is suitably braced.
4. Check that the structural supports under the tank are in good condition.
5. Check that overflows are fitted.
6. If overflow and/or air inlet screens are fitted, check that they have not become blocked.
7. If insulated check that insulation and the manhole is securely fixed and not damaged, if they are damaged then the tank is not in compliance with Byelaw 30.
8. If not insulated in accordance with Byelaw 30, ensure that people can not consume water from the tank. We can advise on upgrading the tank to Byelaw 30 standard.
9. If there is a Condensation Tray with the tank, ensure that it has an overflow fitted and that it has not been damaged.
10. If there are ladders fitted to the tank, ensure that they have not been damaged and are securely fastened to the tank.
11. If the tank has a light duty cover and sited out of doors, check that the cover has not suffered structural damage. (This type of cover is not suitable for potable water or outdoor use).
12. If the area underneath / adjacent to the tank has become water sensitive check that the tank room is bunded with adequate escape ducts.
13. If the tank room is bunded, check that it is in good condition.
14. After maintenance of the tank is complete, ensure that the manhole seal is in tact and the manhole is securely closed.

## **Maintenance on Tanks with Dividers**

Extra care should be taken during the maintenance of tanks with divisions, as maintenance staff will be working in an enclosed space, adjacent to a large volume of water in relation to the size of the space. (See Health & Safety Act)

**Note :** Further information on the Health & Safety aspect, reference water quality is available in BS 6700.

**Do not stand on internal stays while maintenance is being carried out.**

## Glossary Of Terms

**Sectional Tank :** Rectangular fixed container assembled from panels for the storage of water at atmospheric pressure and at a maximum temperature of 30 °C.

**Note :** This temperature is higher than is acceptable for drinking water, which should not normally exceed 20 °C.

**Nominal Capacity :** Volume contained in a tank, measured up to the top edge of the side walls.

**Actual Capacity :** Volume contained in the tank up to the maximum working level, this can be between 10 and 50% less than the Nominal Capacity.

**Bund Wall :** Structure situated underneath water tanks. It's purpose is to protect the building from water damage. All water tanks located above areas that are water sensitive should be banded.

**Ball Valve Housing :** Enclosed chamber containing an access hatch above the level of the cover, permitting the level control mechanism to be mounted at a higher level than would otherwise be possible.

**Vent :** Opening to the atmosphere to allow for the movement of air resulting from changes in the water level so that the water always remains at atmospheric pressure.

**Warning Pipe :** Pipe so fixed that it's outlet, whether inside or outside a building, is in a conspicuous position where the discharge of water can be readily seen.

**Overflow Pipe :** Pipe connected to the tank to discharge any overflow therefrom.

**Division :** Construction of one or more panels within a tank which divides the tank into two separate compartments.

**Note :** In any situation where there is only one water storage tank in a building, it is to be recommend that a weir or a division plate be used. This will facilitate maintenance of the tank without effecting the water supply to the building.

**Weir :** Construction of one or more panels within a tank, which divides the tank but to less than its full depth such that the contents can spill over from one side of the weir to the other.

**Baffle :** Construction of one or more panels within a tank, which partially subdivides the tank in order to increase the length of the flowpath between the inlet and the outlet from the tank.

**Leakage Test :** The duration of the test should be a minimum of 24 hours, commencing at least 2 hours after the tank has been filled. The test shall be carried out within 10 days of erection unless the manufacturer agrees to a longer period after assembly. The tank should be inspected at regular intervals and not deserted during commissioning (first filling with water). The leakage test is not carried out by Nicholson Plastics Ltd.

**BS 7491 : Part 3 : 1994 :** Glass fibre reinforced plastics cisterns for cold water storage. Part 3 Specification for sectional tanks.

**BS 6700 : 1997 :** Specification for design, installation, testing and maintenance of services supplying water for domestic use within building and their curtilages.